

RIBW01B-EN2

Enclosed EnOcean® Enabled Wireless Relay Transceiver / Repeater 20 Amp SPDT, 120 Vac Power, with Dry Contact Input

RIBW208B-EN2

Enclosed EnOcean® Enabled Wireless Relay Transceiver / Repeater 20 Amp SPDT, 208 Vac Power, with Dry Contact Input

RIBW240B-EN2

Enclosed EnOcean® Enabled Wireless Relay Transceiver / Repeater 20 Amp SPDT, 240 Vac Power, with Dry Contact Input

RIBW277B-EN2

Enclosed EnOcean® Enabled Wireless Relay Transceiver / Repeater 20 Amp SPDT, 277 Vac Power, with Dry Contact Input

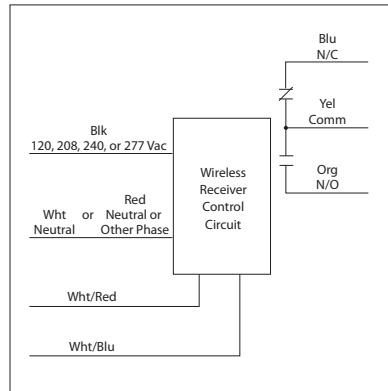

Wireless Control Relays with Two-Way Communication



Relay has built-in repeater function. Relay receives signal from wireless switch transmitter and rebroadcasts the signal to the next relay receiver.

Specifications

- # Relays & Contact Type: One (1) SPDT Continuous Duty Coil
- Expected Relay Life: 10 million cycles minimum mechanical
- Operating Temperature: -30 to 140° F
- Humidity Range: 5 to 95% (noncondensing)
- Red LED: Relay Status / Learn Mode Status (Flashing)
- Dimensions: 2.30" x 3.20" x 1.80" with .50" NPT Nipple
- Wires: 16", 600V Rated
- Approvals: UL Listed, UL916, C-UL, RoHS
- Housing Rating: UL Accepted for Use in Plenum, NEMA 1
- Gold Flash: No
- Override Switch: No
- Frequency: 315 MHz
- Receiver Sensitivity: -93 dBm typical
- Conducted Power: 5 mW typical
- Built-in Switch Modes: Rocker, Momentary, and Toggle

- Contact Ratings:**
- 20 Amp Resistive @ 277 Vac
 - 5 Amp Resistive @ 480 Vac
 - 20 Amp Ballast @ 277 Vac
 - 16 Amp Electronic Ballast @ 277 Vac (N/O)
 - 10 Amp Tungsten @ 120 Vac (N/O)
 - 770 VA Pilot Duty @ 120 Vac
 - 1,110 VA Pilot Duty @ 277 Vac
 - 2 HP @ 277 Vac
 - 1 HP @ 120 Vac

- Power Input Ratings:**
- 73 mA @ 120 Vac; 60 Hz (RIBW01B-EN2)
 - 80 mA @ 208 Vac; 60 Hz (RIBW208B-EN2)
 - 80 mA @ 240 Vac; 60 Hz (RIBW240B-EN2)
 - 80 mA @ 277 Vac; 60 Hz (RIBW277B-EN2)

- Notes:**
- Compatible with EnOcean® 315 MHz Switches/Transmitters.
 - Typical range: 50-150 ft.
 - Open area transmission could be farther. Consult factory for more information.
 - Repeater function only rebroadcasts original EnOcean® transmission. Up to two repeaters can be used.
 - For setup instructions, see website for -EN2 Series Application Manual: www.functionaldevices.com/pdf/manuals/B1594A.pdf or scan QR code with your smart phone.



Application for Wireless Control & Feedback in a Building Automation System

